

Neural Nets

**The Hype and the Reality –
from an industrial perspective**

Graham Hesketh CEng MIEE

**Team Leader ~ Information Engineering
Strategic Research Centre
Rolls-Royce, Derby**

Gratuitious Equations

Prediction

$$\hat{\mathbf{x}}(k | k-1) = \mathbf{A}\hat{\mathbf{x}}(k-1 | k-1)$$

$$\mathbf{P}(k | k-1) = \mathbf{A}\mathbf{P}(k-1 | k-1)\mathbf{A}^T + \mathbf{Q}(k-1)$$

Updating (correction)

$$\mathbf{K} = \mathbf{P}(k | k-1)\mathbf{C}^T [\mathbf{C}\mathbf{P}(k | k-1)\mathbf{C}^T + \mathbf{R}(k)]^{-1}$$

$$\hat{\mathbf{x}}(k | k) = \hat{\mathbf{x}}(k | k-1) + \mathbf{K}[y(k) - \mathbf{C}\hat{\mathbf{x}}(k | k-1)]$$

$$\mathbf{P}(k | k) = \mathbf{P}(k | k-1) - \mathbf{K}\mathbf{C}\mathbf{P}(k | k-1)$$

About me

- **Mathematician at heart**

- A-level Maths, Further Maths and Physics (Leigh Grammar School, 73-74)

- **Physicist by training**

- Physics / Physical Electronics Degree (1st Class Hons, Bath, 75-79)

- **Information Engineer by vocation**

- AEA Technology (UKAEA, Harwell, 79-97)
- Rolls-Royce (Strategic Research Centre, Derby, 97-present)
- Chairman of NCAF (Natural Computing Applications Forum, formerly the Neural Computing Applications Forum) - active committee member for 10 years

Early History

- In the 1930's Turing, McCulloch, Pitts and Hebb began to research ways to mimic the operation of the human brain.
- The seminal year for the development of the “science of mind” was 1943 when McCulloch and Pitts modelled a simple neural network with electrical circuits.
- First learning rule (Hebb 1949).
- The first neurocomputers (electromechanical)
 - ⇒ *Snark* (Minsky 1954)
 - ⇒ *Perceptron Mark I* (Rosenblatt 1958)
 - ⇒ *Adaline* & LMS learning (Widrow & Hoff 1959)
- Widrow founded the first neurocomputer company: the Memistor Corporation.
- **Era of neurocomputing had begun!**

Middle History

- In 1969 Minsky and Papert published *Perceptrons* in which the glaring limitations of the simple perceptron were exposed.
- After this there followed 13 years of hibernation known as the “disillusioned years”, during which there was virtually no financial support. Nevertheless, some research continued – in 1974 Werbos introduced backpropagation and in 1975 Fukushima created the first multi-layered network, the Cognitron.
- The turning point came in 1982 when Hopfield delivered his seminal paper to the National Academy of Sciences. In the same year Kohonen described his self-organizing feature map.
- In 1985 Parker and Le Cun rediscovered backpropagation and in 1986 Rumelhart and McClelland popularised it in their famous book *Parallel Distributed Processing*.
- From 1987 onwards there has been an explosion in research on neural networks, new journals, conferences, applications, products, industrial initiatives, and start-up companies.



- **Non-profit making organisation founded 1990 as a support group for users of NeuralWorks software**
- **Hosts three 2-day meetings per year at varied UK locations (from Exeter to Strathclyde)**
Next one is Swansea 15-16 Sep 2004
- **Promotes exchange of ideas and information between academics and industrialists – helped to de-hype the NN revolution**
- **Has led to successful partnerships**

ESPRIT 2 Project – ANNIE (1989)

- **Visual inspection of the quality of solder joints**

- ⇒ Early efforts had 20 x 20 pixel inputs feeding directly into a vanilla MLP
- ⇒ Later work succeeded with “shared weights”

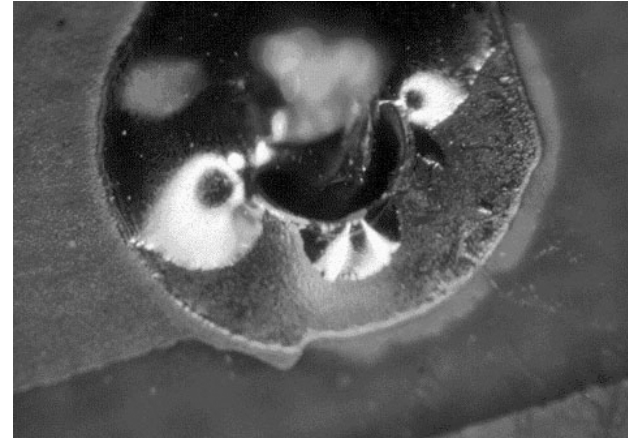

- **Robot guidance for collision avoidance**

- **ReNDeR – Reversible Non-linear Dimensionality Reduction**

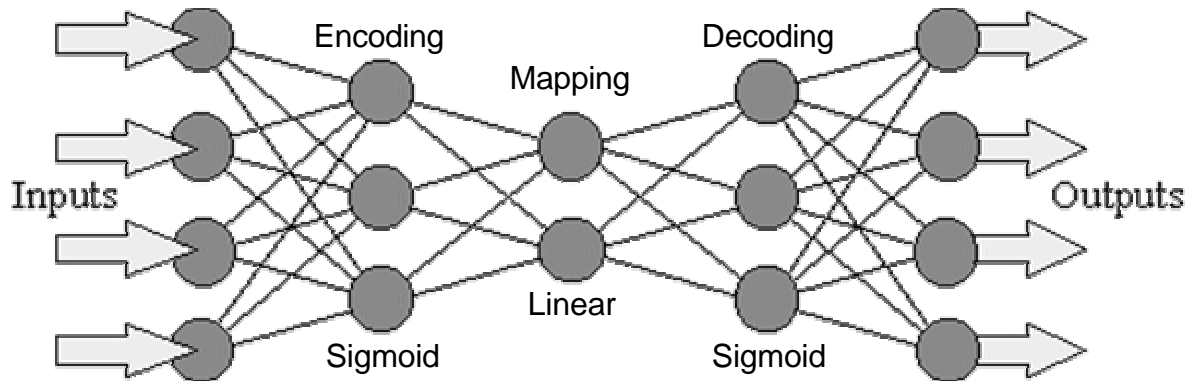

Auto-associative 5-layer network



The *CounterMatch* Saga

Involving ...

- A world-class neural network application (dynamic signature verification)
- A heart-warming tale of bureaucratic intransigence



History of Countermatch: Concept

- **1990 – 1991**
Professor Colin Windsor
was developing an
elastic matching neural
network for gas
chromatography
(MatchFinder)

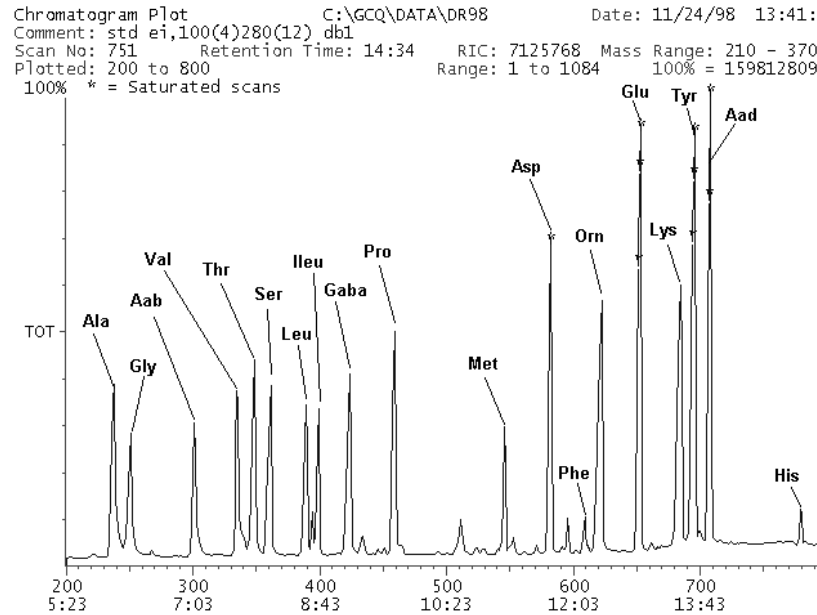

I hereby confirm order number [110349]

- **February 1992**
Applied the technique to
signatures and proved
the feasibility

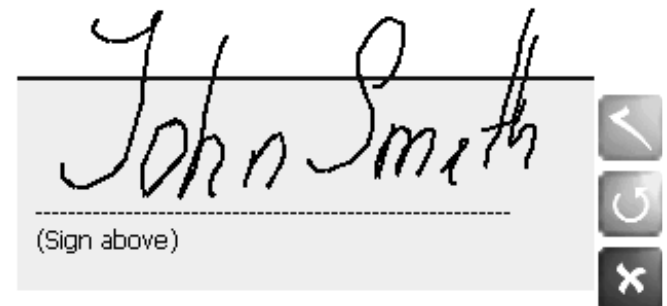

History of Countermatch: Elastic Matching Neural Network

- **Dynamic Signature Verification**
 - ⇒ collects signatures in real-time
- **Does *not* extract features**
 - ⇒ matches whole signatures
- **Very tolerant of “natural” variations**
- **Sensitive to deliberate or “unnatural” variations**

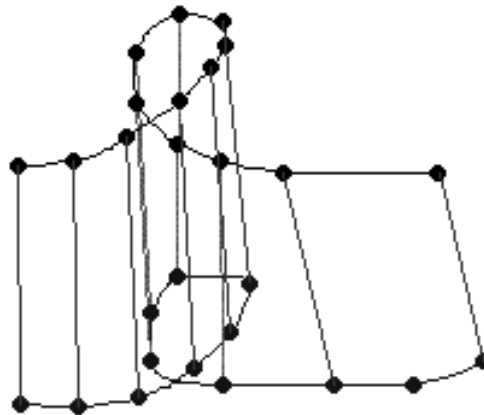

History of Countermatch: Initial Development

- **April 1992**

- ⇒ Rewritten in C
- ⇒ LCD signature capture tablet
- ⇒ Trained neural network model



- **September 1992**

- ⇒ Internal trial at Harwell
- ⇒ Live television demonstration on “Tomorrow’s World”

BBC Presenters
Howard Stableford and
Judith Hann



History of Countermatch: Harwell Trial Results



History of Countermatch: Exploitation (1)

- 1993

- ⇒ Shown to financial, retail and government sectors

- **Reservations**

- ⇒ Large scale (did not want to be first)

- ⇒ Concerned about public reaction

- ⇒ No statistics to validate performance in the public domain



History of Countermatch: Exploitation (2)

- **December 1993**
 - ⇒ Seen by the UK Employment Service
- **Requirements**
 - ⇒ Inking pen writing on standard forms
 - ⇒ Networked signing stations dealing with thousands of clients
 - ⇒ Very simple interface
 - ⇒ Must not disrupt the normal operations of the office

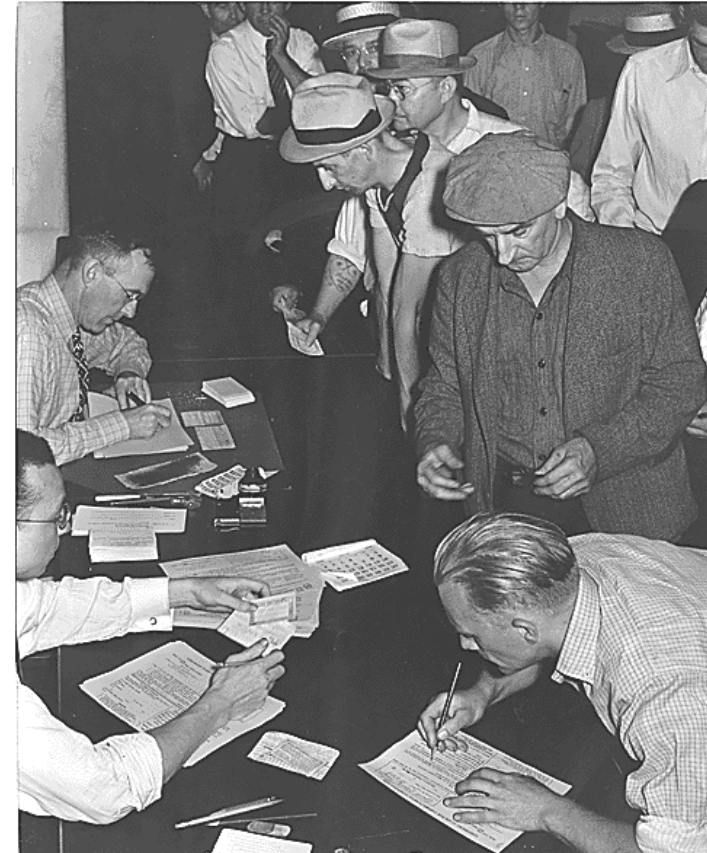

Employment Service Trial: Details

- **September - November 1994**
 - ⇒ Two offices: Liverpool and Tyneside
 - ⇒ 6 PCs in each office
 - ⇒ Signing every two weeks
 - ⇒ 8,000 clients in total
 - ⇒ 36,000 signature verifications
- **Worlds largest and most realistic public trial of signature verification**



Employment Service Trial: Results

- **95% of all sign-on cases accepted**
 - ⇒ 94% of all successful sign-ons required only one signature attempt
- **Around 7 rejections per day (out of a total of over 300 sign-ons)**
- **Of the rejections, only 2-3 per fortnight were Countermatch failures (false reject figure of around 0.1%)**



Employment Service Trial: Benefits

- Identified fraudulent clients
- Had noticeable deterrent effect
- Reduced clerical error
- Boosted morale
- Was easy to install and use
- Fitted existing procedures
- Client reactions were favourable (well, those from the genuine clients anyway)

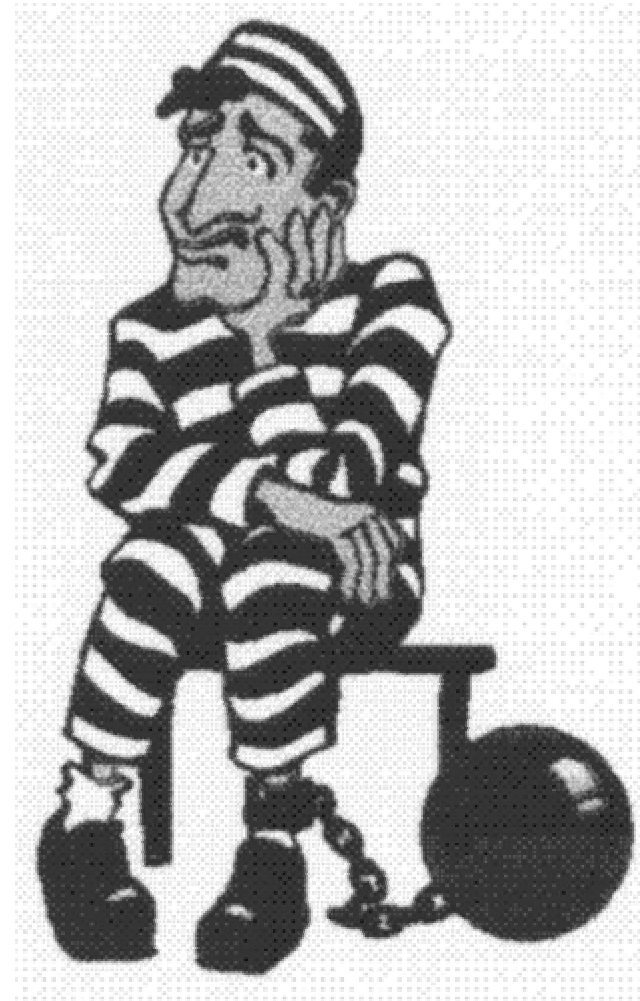

Employment Service Trial: Update (1996)

- **One year later both offices were still using the software (neither wanted to stop)**
- **20,000 clients had been enrolled**
- **190,000 signature verifications had been performed**
- **Every verification was logged for subsequent auditing**

Update (1997)

- **Government changed the Benefits system**
- **Returned Unemployment Benefit and Income Support to the Benefits Agency**
- **Removed the financial incentive from the ES to implement the system**

UK Government Support

- **In the mid 1990's the DTI provided Neural Computing: Learning Solutions**
 - ⇒ This produced the DTI Best Practice Guidelines for Neural Computing Applications
 - ⇒ Thoroughly reworked and republished as *A Guide to Neural Computing Applications* by Lionel Tarassenko
- **Around the same time EPSRC launched *Neural Computing – the Key Questions***
 - ⇒ A managed programme of academic/industrial research projects

Sharp LogiCook (1995)

- The world's first neural network controlled microwave oven (R-4N76).
- Sharp's first product to be developed outside of Japan (with Tarassenko from Oxford Uni).
- Sharp UK's most successful microwave oven in the medium price range for two consecutive years.

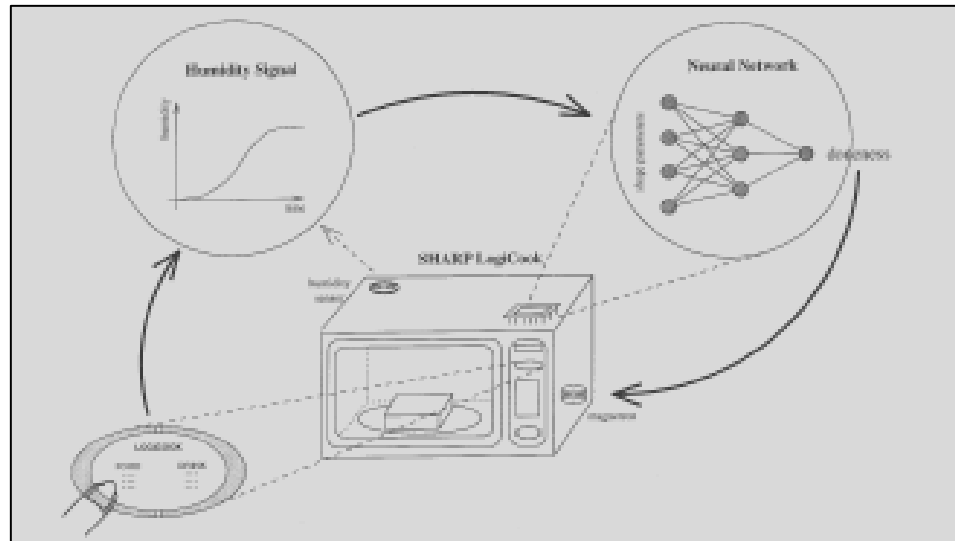

Oxford BioSignals



- **Successful spin-out from Oxford University led by Lionel Tarassenko**
- **BioSleep and BioSomnia products for EEG sleep analysis**
- **BioSigns – a multi-parameter monitoring device for Intensive Care Units using neural networks to fuse different physiological parameters**
- **QUICK Technology™ designed for jet engine health monitoring**
- **Won the Rolls-Royce Chairman's Team Award for Technical Innovation in 2001**

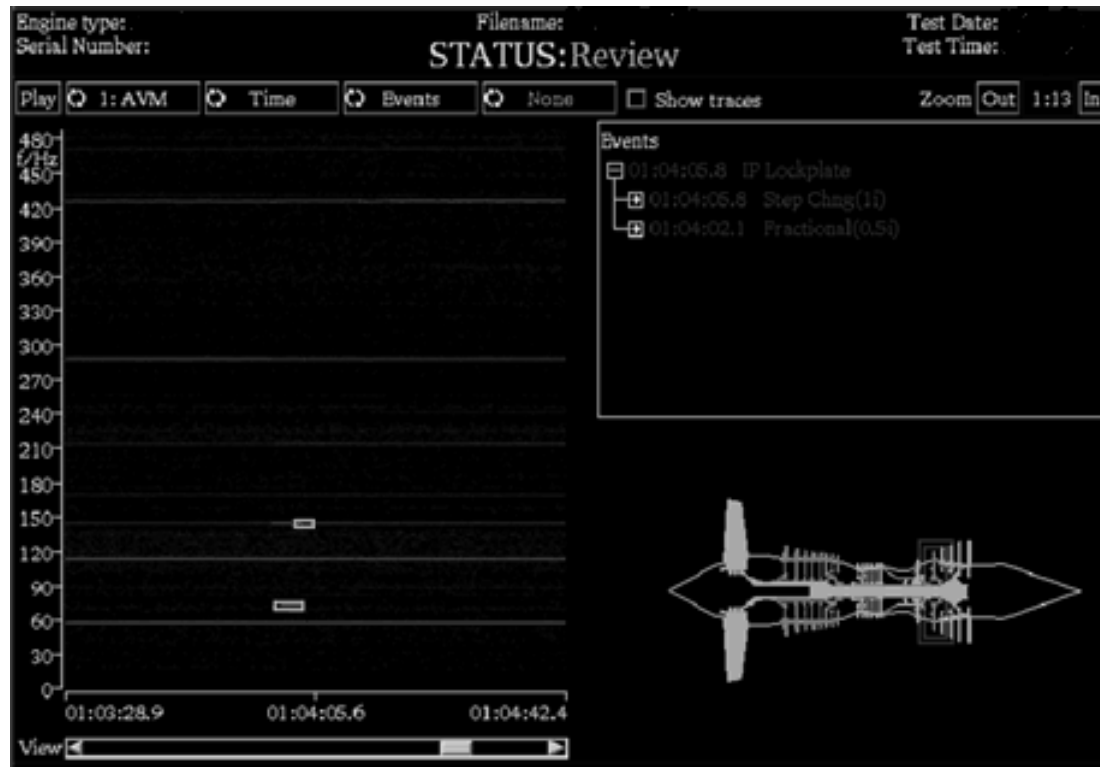

Rolls-Royce 3-shaft engine

L

High Pressure Turbine

BLOW

SQUEEZE

BANG!

SUCK

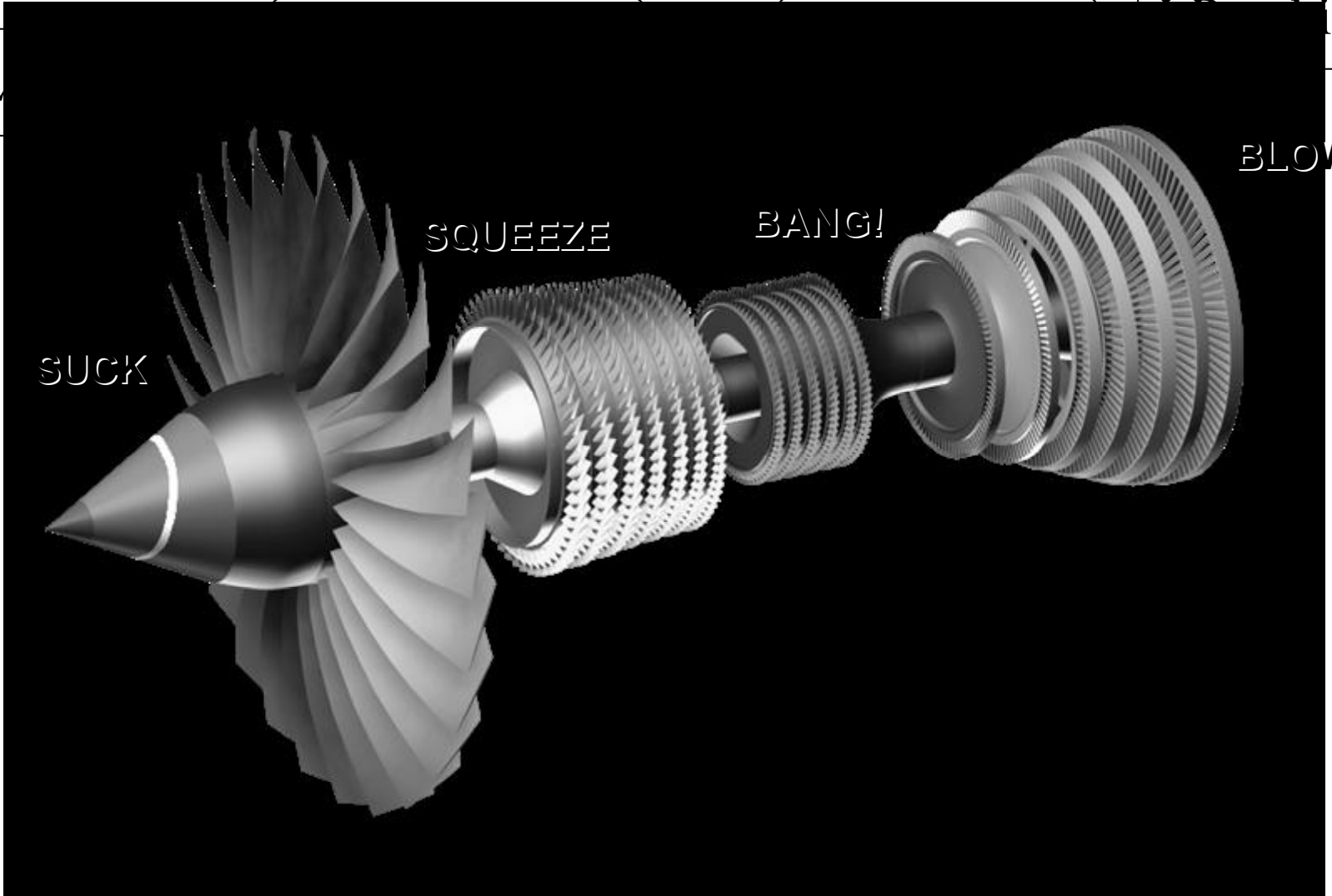

Engine Health Monitoring - Overview

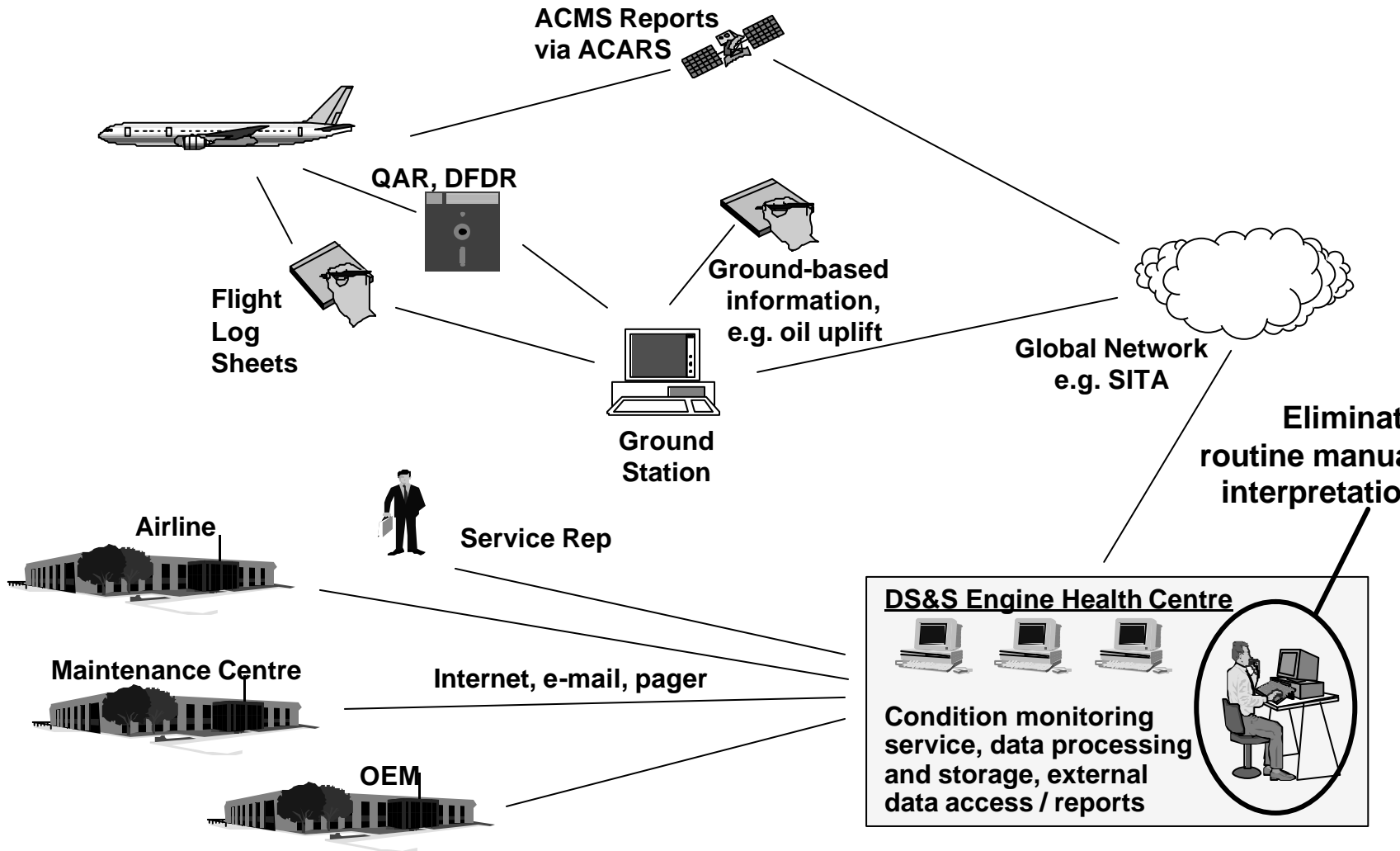

Engine Health Monitoring - process

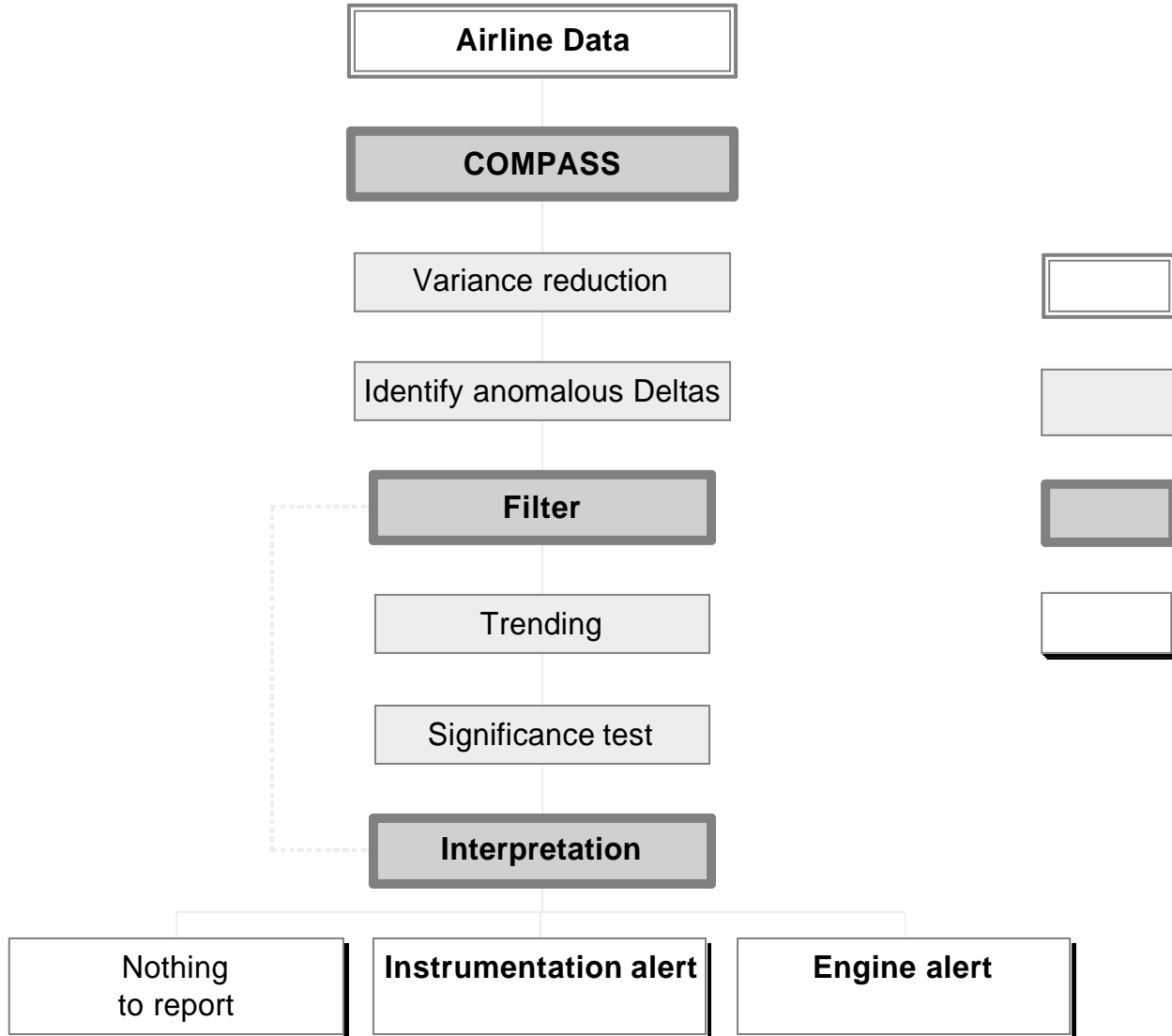

Delta TGT values with model correction

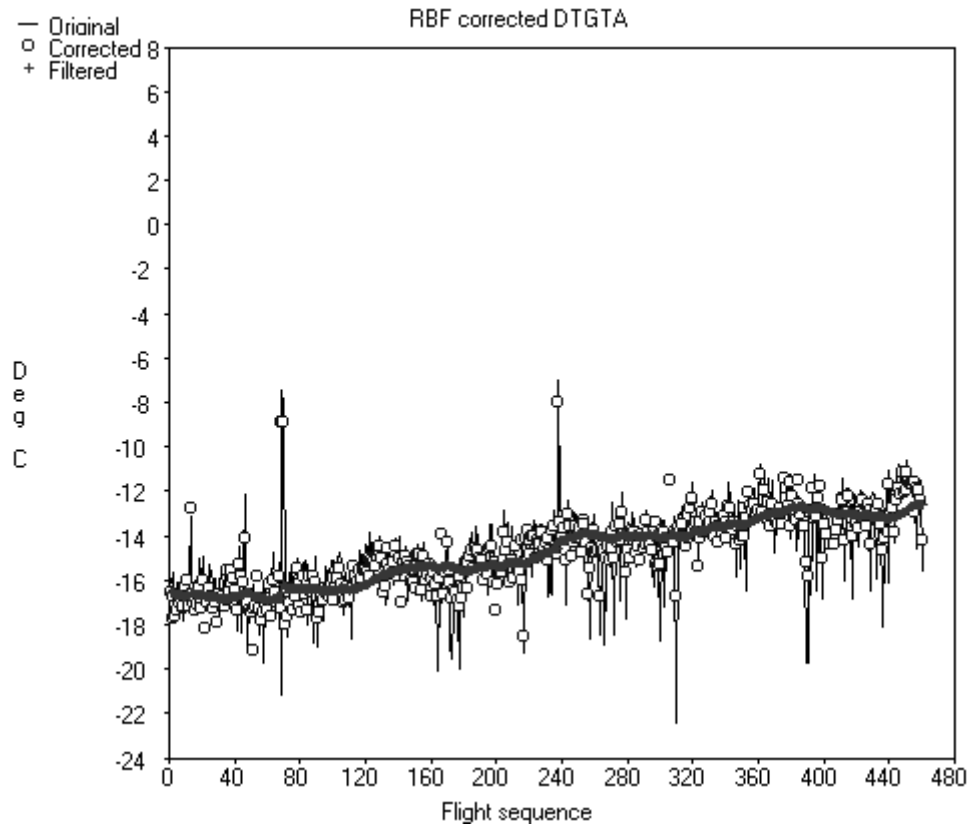

Delta LP shaft speed – *original data*

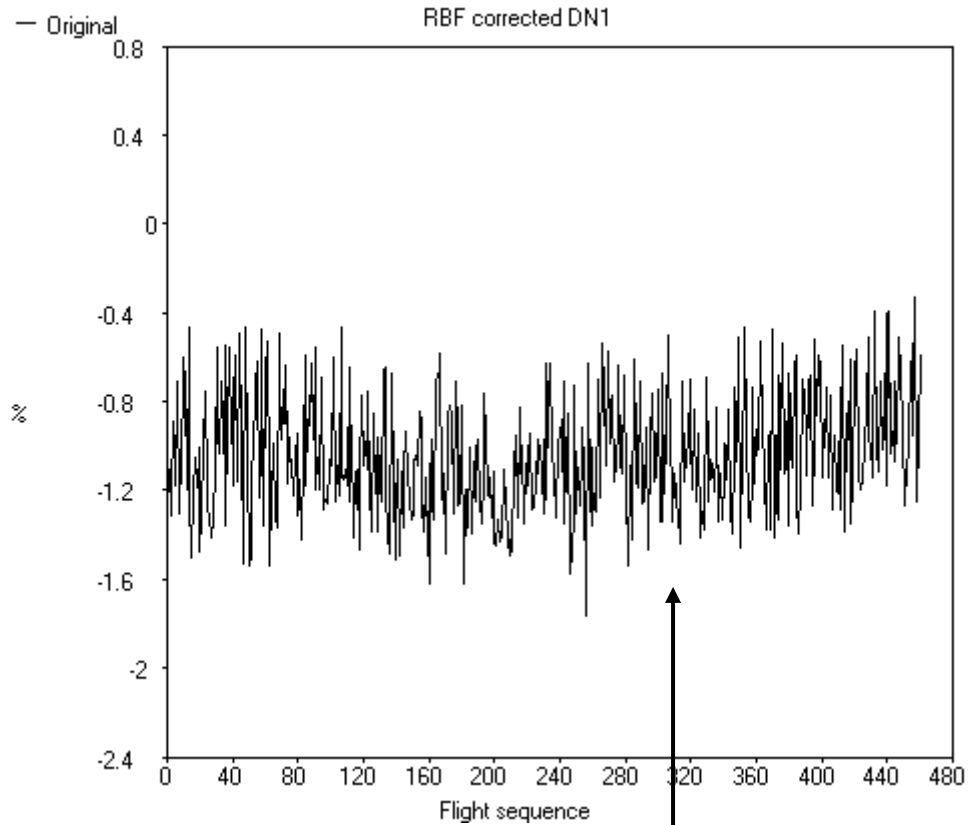

Watch this space

Delta LP shaft speed – *corrected by model*

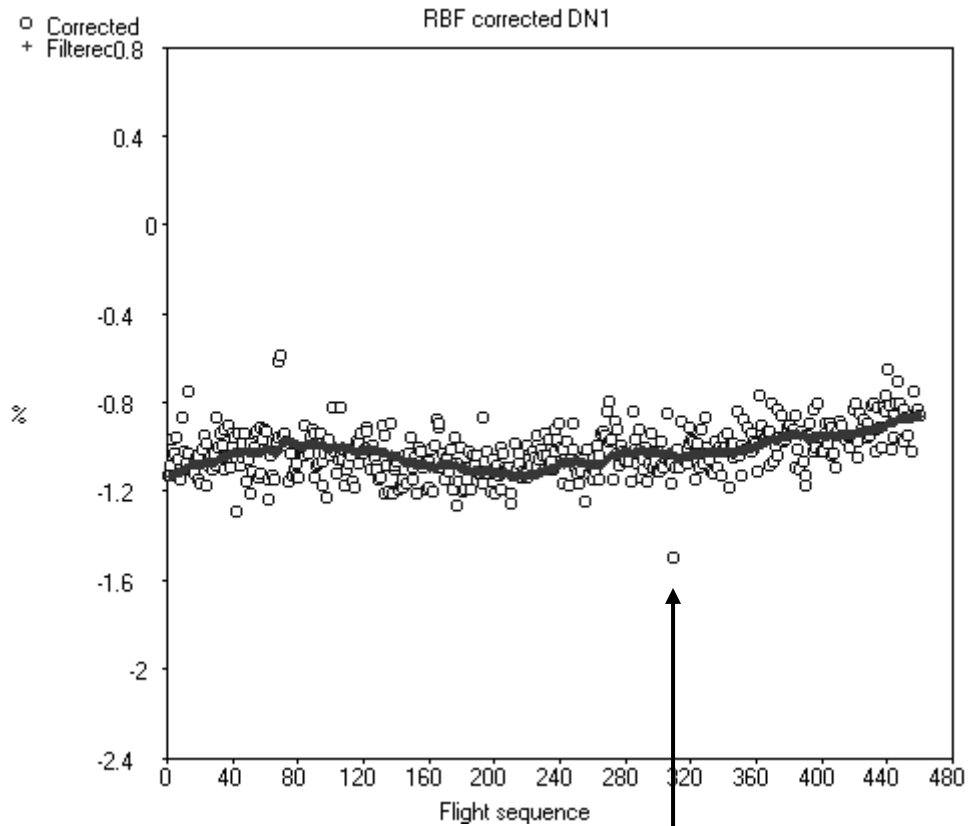

Sensor or engine?

Repeated evidence (DN2) from same flight

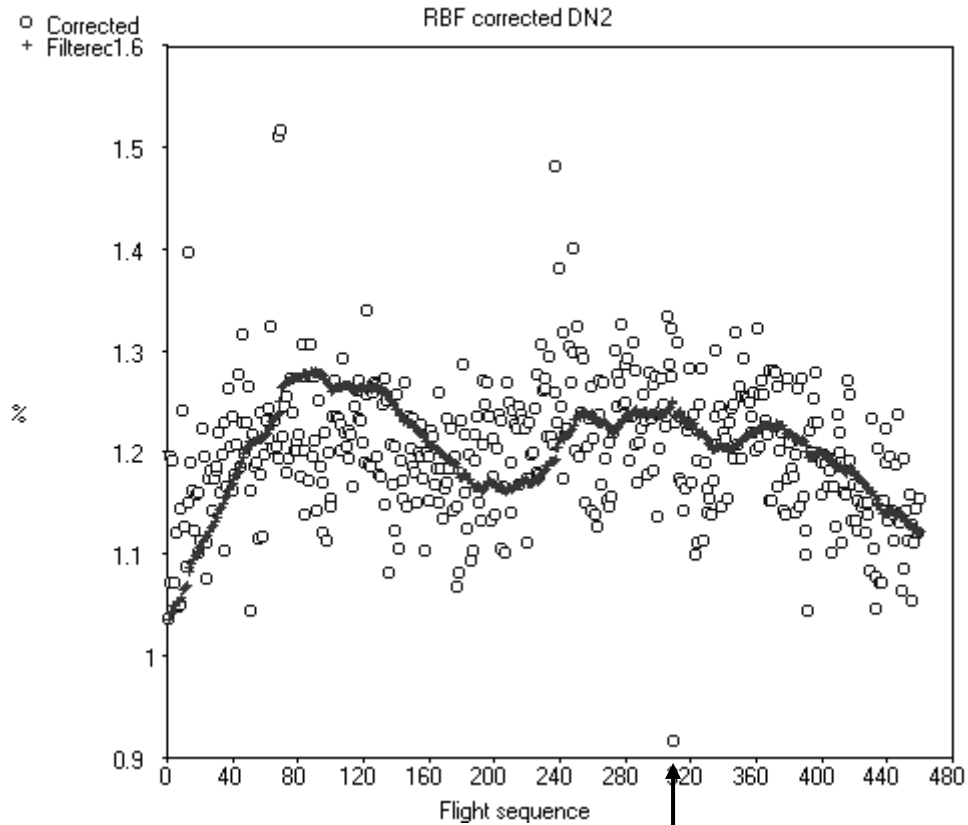

Delta IP shaft speed - *original data*

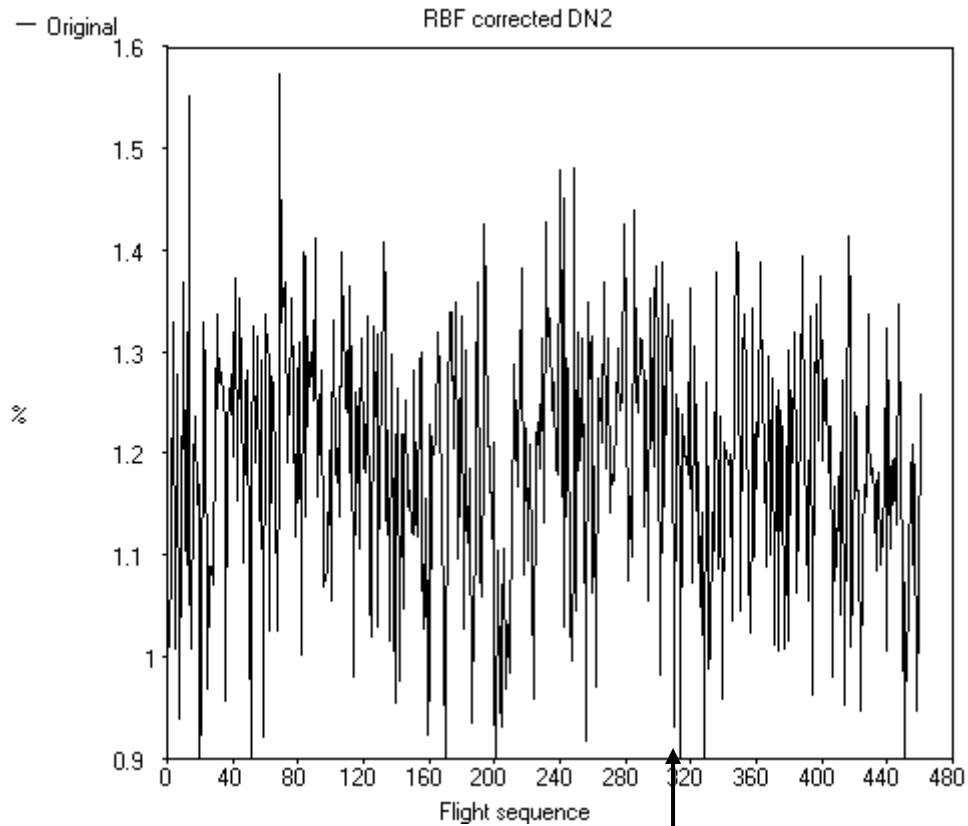

Needle in haystack?

EHM - Vibration

- A key parameter!

- ⇒ Out of balance
- ⇒ Bearing failures
- ⇒ Physical damage to rotating components
- ⇒ Fluids (e.g. oil) in drums
- ⇒ Seal rubs

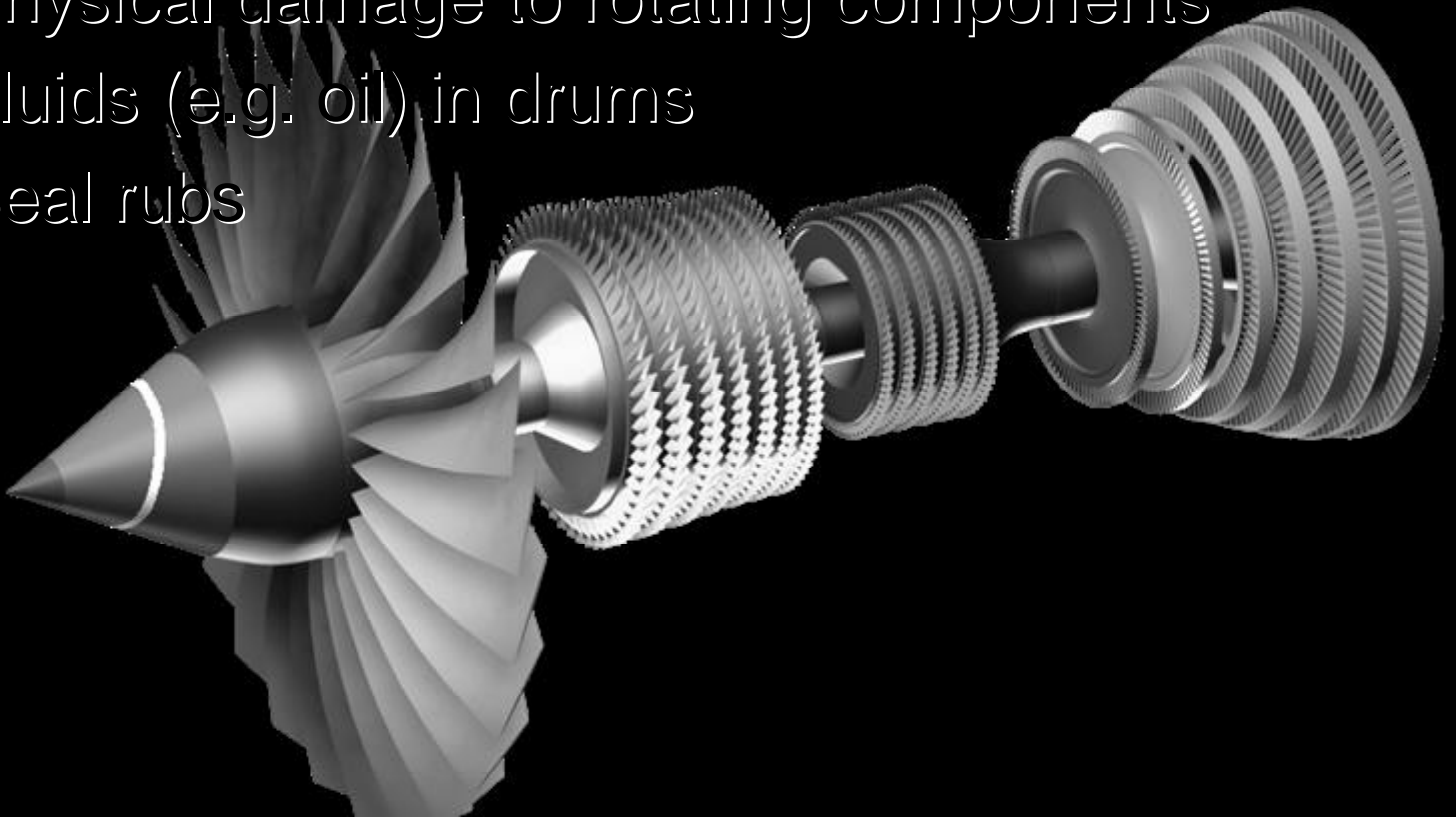

ZMod



Novelty Detection – the motivation

The problem stated

With high-integrity systems such as jet engines, conventional fault detection methods have limited capability

- the most important examples (i.e. the abnormalities) are very rare
- some of the fault conditions may not have been seen before

Solution

Learn a description of normality and test for *novelty* against this

“... leading-edge methods of computational intelligence will be developed ... to perform comprehensive whole engine data analysis and interpretation, with high confidence levels”

Phil Ruffles, Director of Engineering and Technology, Rolls-Royce

Engine type:
Serial Number:

Filename:
STATUS:

Test Date:
Test Time:

QUINCE

Version 1.1



Copyright 1996–9 Oxford University Engineering Department

STATUS: Below Limits

Vibration Diagnosis

Engine Acceptable

STATUS: Above Limits

Vibration Diagnosis

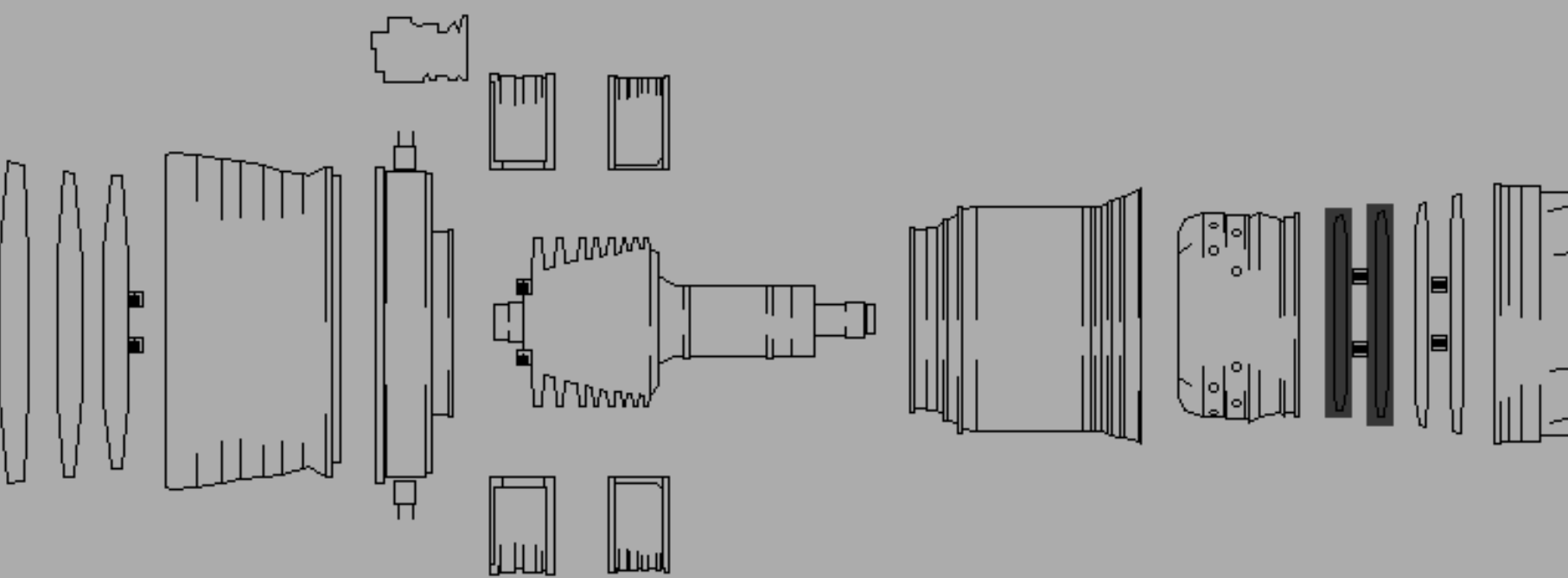

Copyright 1996–9 Oxford University Engineering Department

The engine has not satisfied the contractual requirements. Recommended action: rebalance the HP turbine.

STATUS: Above Limits

Feature Analysis Summary

	DH Vertical		EMS Vertical	
	Acceleration 1250 Hz	Deceleration 1250 Hz	Acceleration 1250 Hz	Deceleration 1250 Hz
Shape	Weak	Weak	Weak	Strong
Broadband	Weak	Strong	Not done	Not done
Dropout	Strong	Weak	Strong	Strong
Sideband	Strong	Strong	Strong	Strong
Multiple	Absent	Absent	Absent	Absent
Fractional	Strong	Strong	Strong	Strong
Sum/Diff	NYA	NYA	NYA	NYA
Fixed Freq	Absent	Absent	Absent	Absent
Noise	Absent	Absent	Absent	Absent

Shape Analysis

Gauge: DH Vertical Data type: Acceleration

Toggle highlights

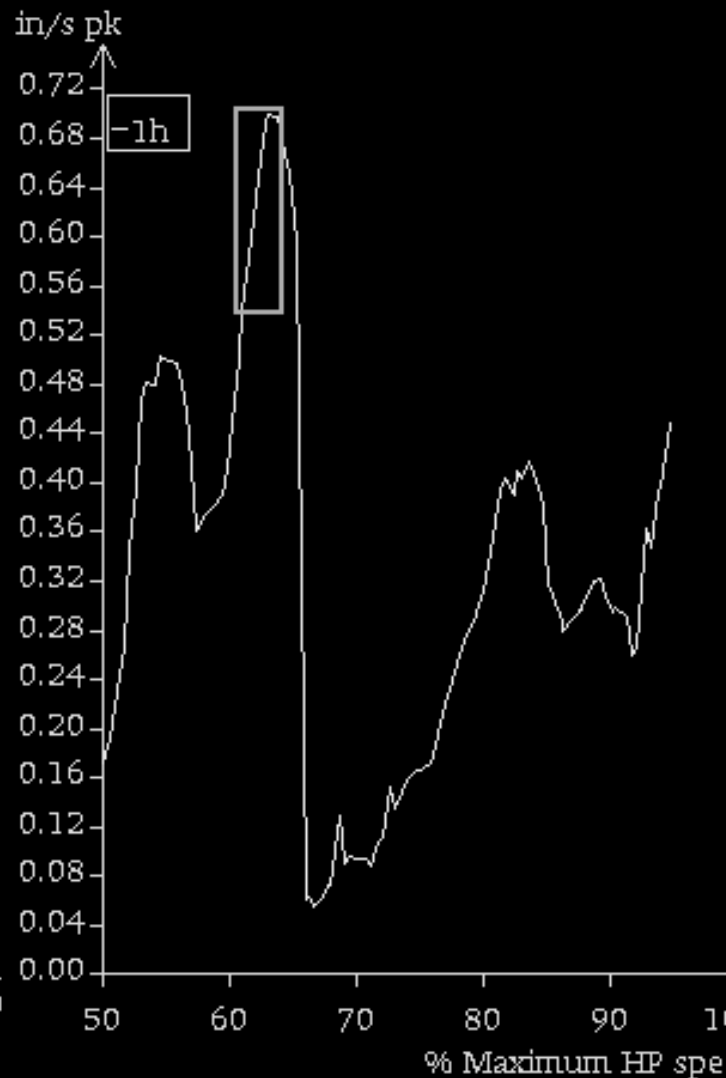
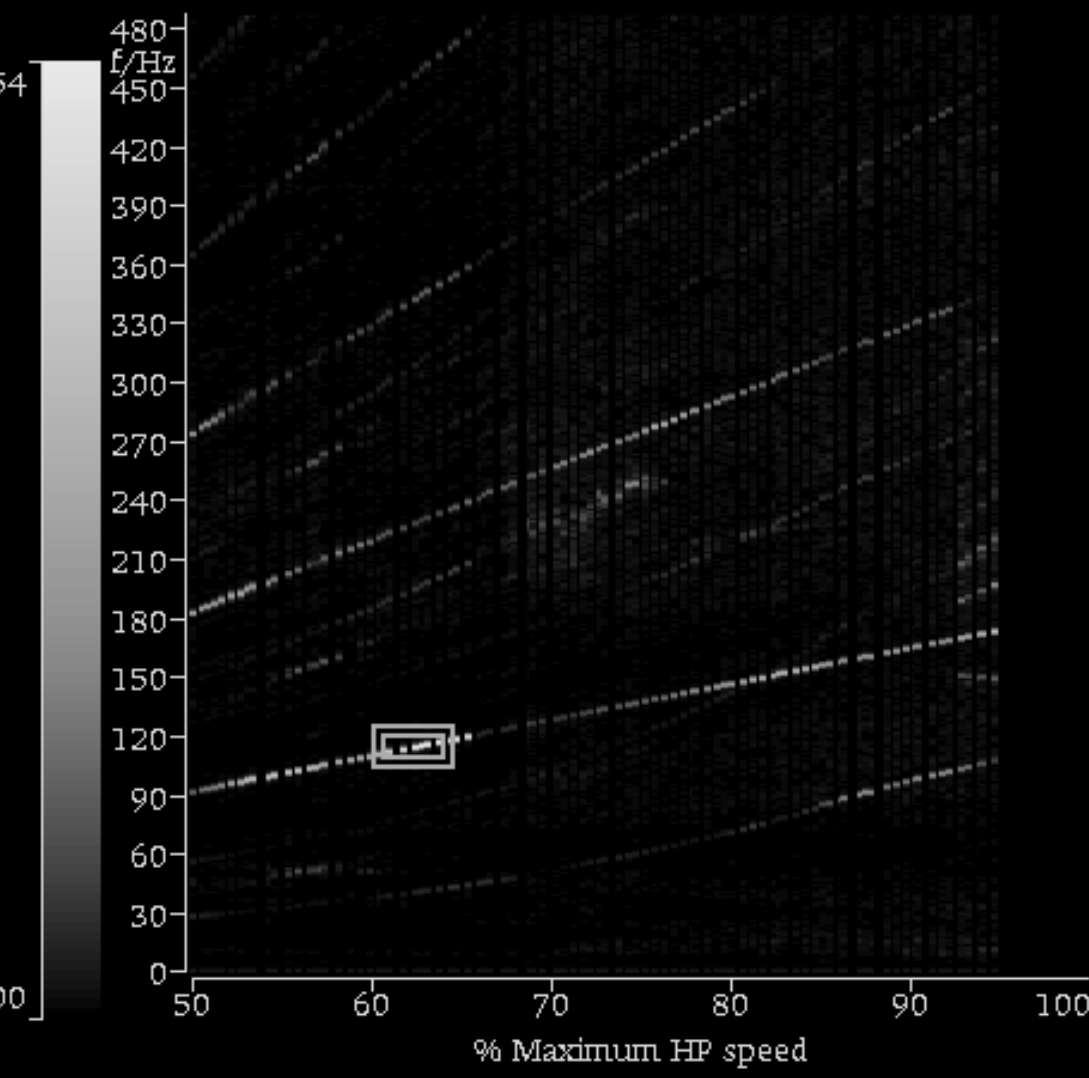

STATUS: Above Limits

Dropout Analysis

Gauge: DH Vertical Data type: Acceleration

Toggle highlights

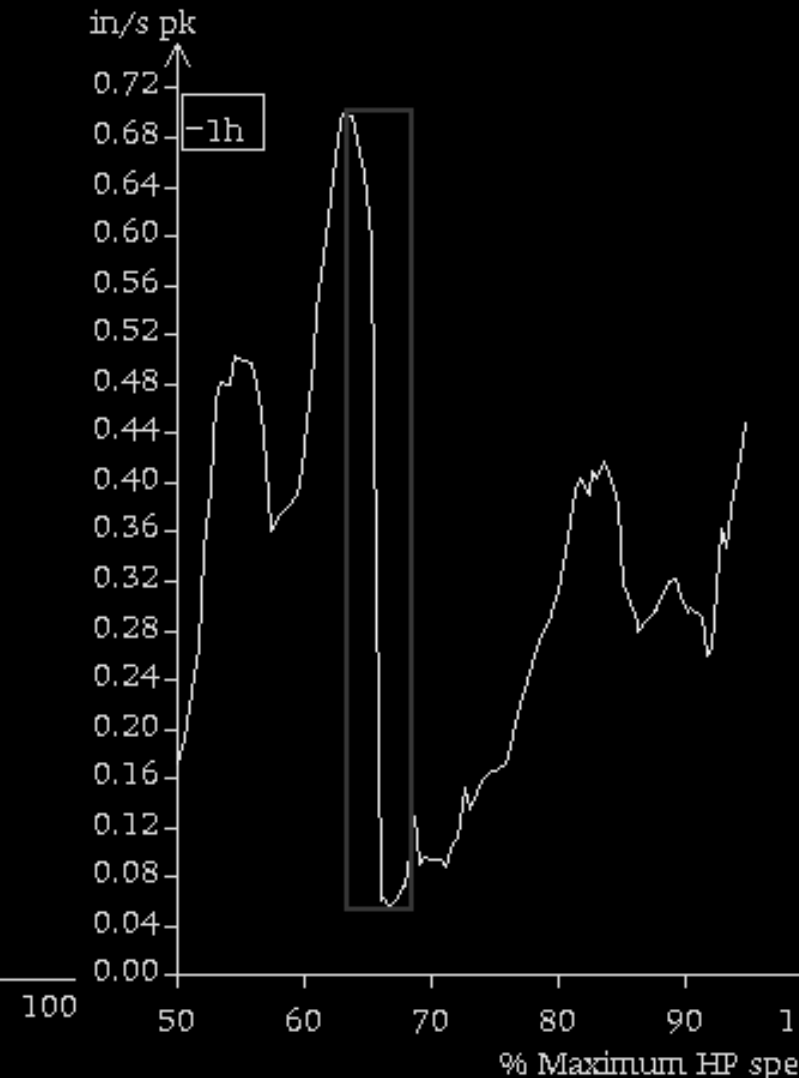
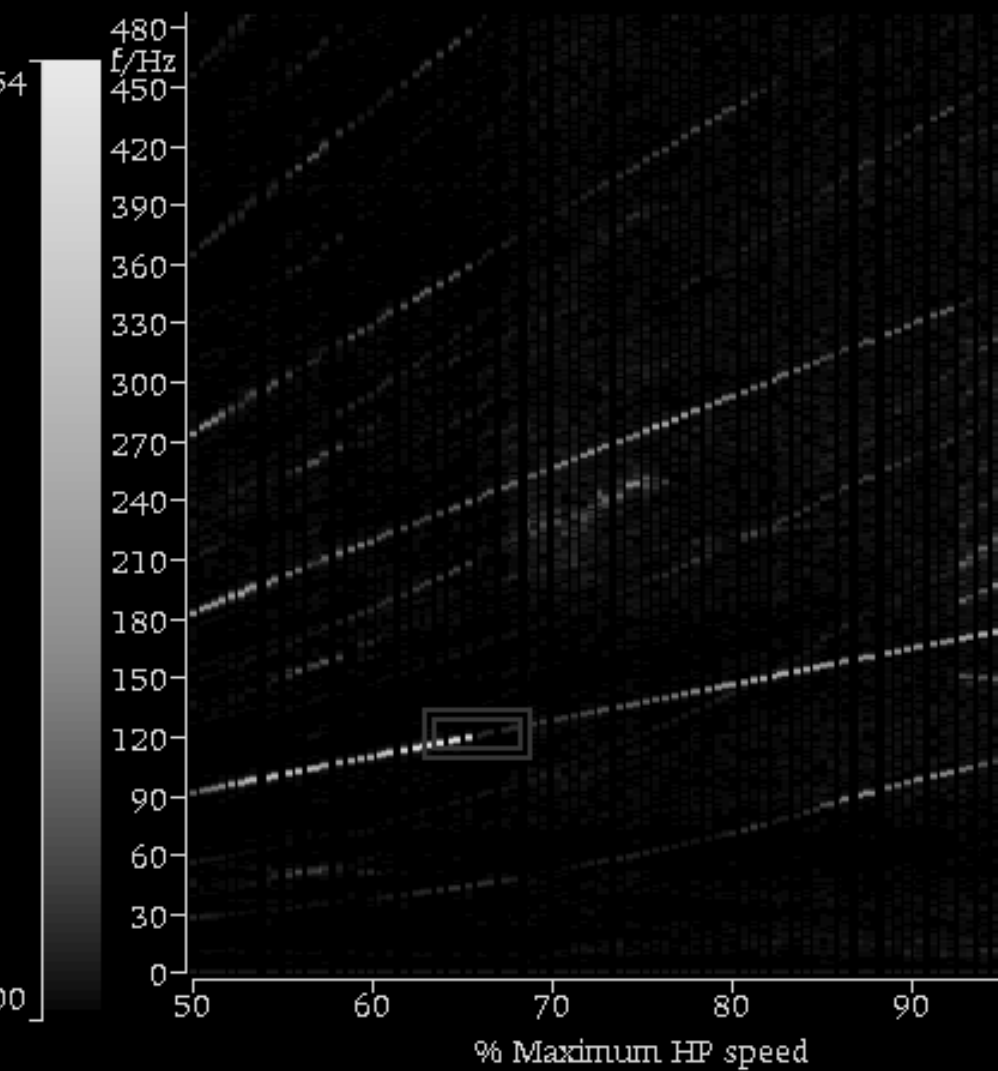

STATUS: Above Limits

Sideband Analysis

Gauge: DH Vertical Data type: Acceleration

Toggle highlights

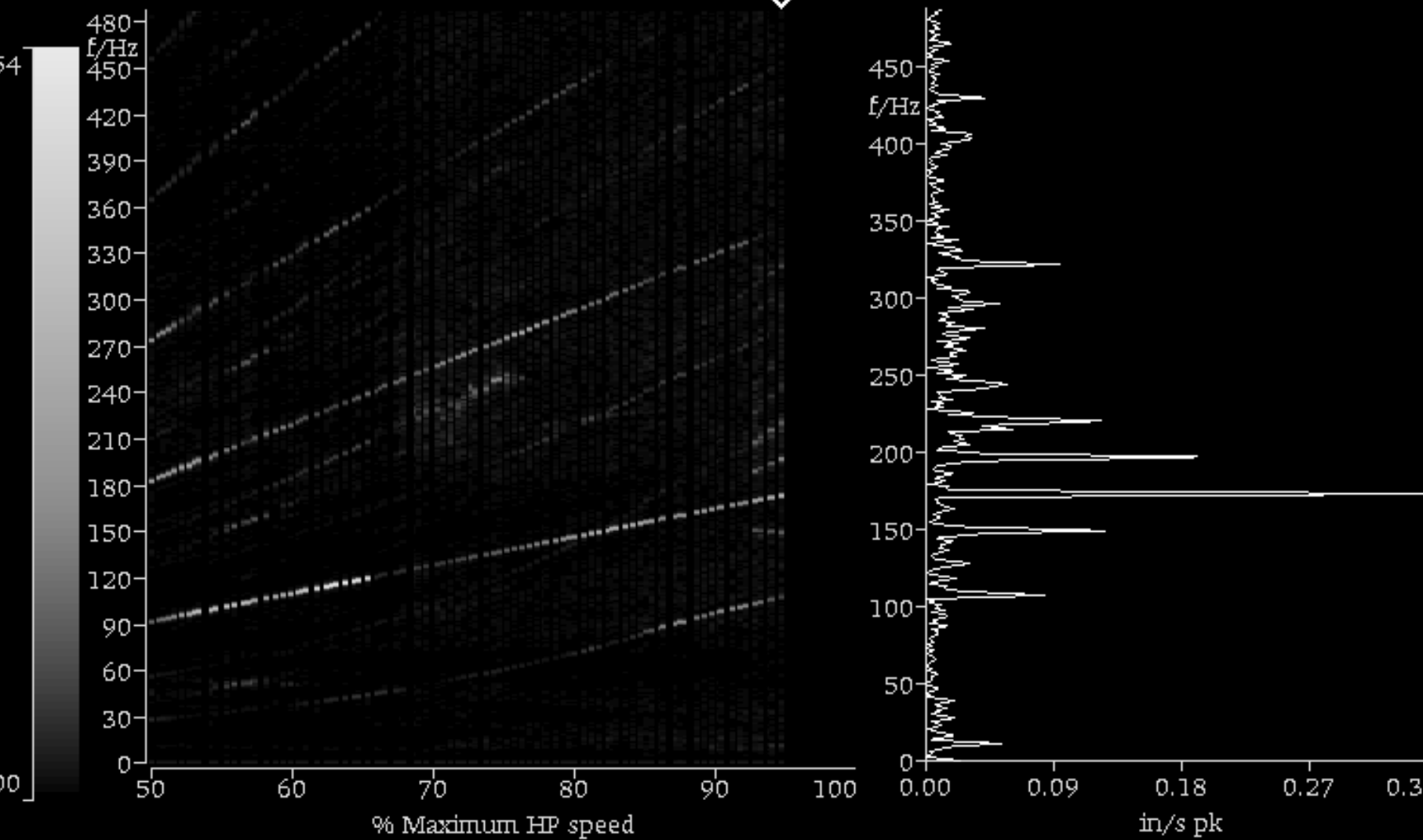

STATUS: Above Limits

Sideband Analysis

Gauge: DH Vertical Data type: Acceleration

Toggle highlights

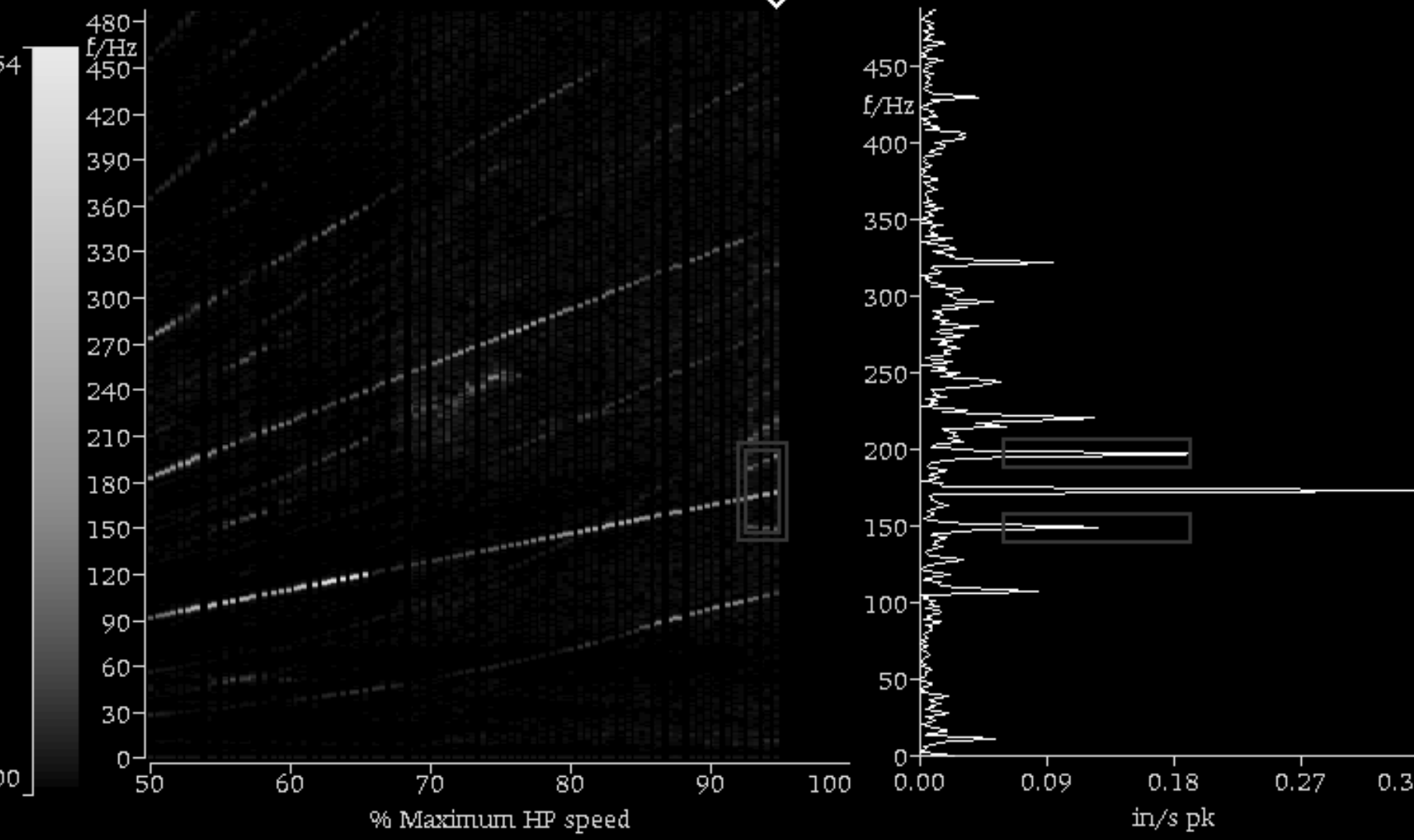

Engine type: PEGASUS [406/105]	Filename: vam200/Demo/ex04.dgu	Test Date: 01/07/93
Serial Number: 11064/	STATUS: Above Limits	Test Time: 08:01:13
Symptoms Table		
	HP table	LP table
First EO	Weak	Absent
Second EO	Absent	Absent
Multiples EO	Absent	Absent
Half EO	Strong	Not done
Fractional EO	Not done	Not done
Divergent sidebands	Strong	Not done
Parallel sidebands	Not done	Not done
Sub EO	Not done	Not done
Fixed frequency	Absent	Not done
Sum or difference	Not done	Not done
Constant EO	Absent	Absent
Beating EO	Not done	Not done
High spectral	Absent	Not done
Resonant amp step	Weak	Not done
EO step	Absent	Not done
Discrete tone	Not done	Not done
Template match		

Commercial NN Success Stories (US)

- SmartPackets using ANN in WiFi packet sizing
- SurfControl Web Filter
- Mars Express (Mission to Mars)
- HNC lending decision system
- Fair Isaac
- Symantec Norton Antivirus
- Babel Speech Recognition Solution
- Checkmate Intrusion Protection, Psynapse Technologies
- ... many others
- Estimated that over 80% of Fortune 500 companies have neural net R&D programs

What would we really like?

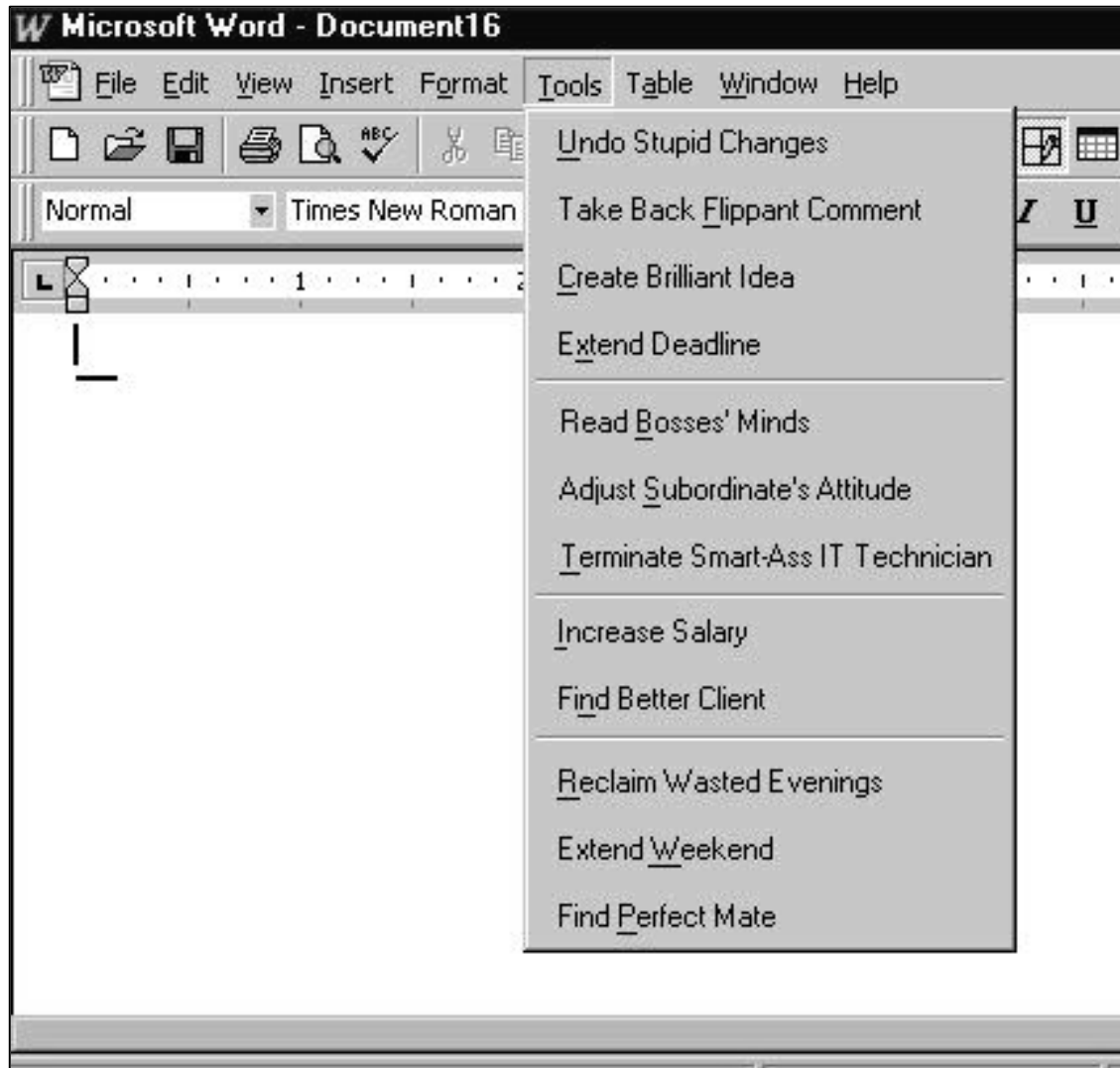

What have we nearly got now?

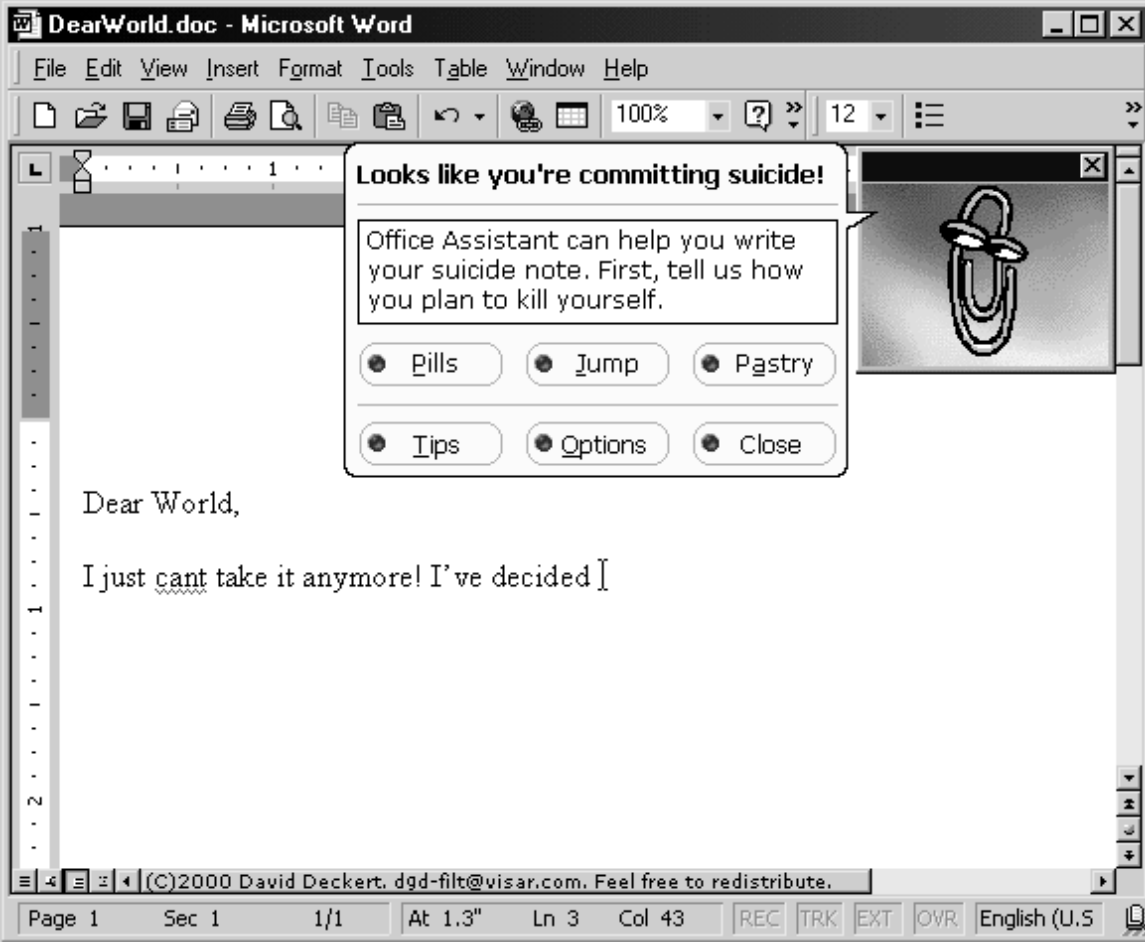

Avoidable frustration?



Profits for all?

- Sports betting software (dogs, horses, football ...)
- Countless examples, many purporting to use neural networks
- Often use NN as a marketing tool
- Some have scientific credibility e.g. McCabe's Artificially Intelligent Tipster (MAIT)
Reviewed in NewScientist.com, Dec 2002
<http://www.newscientist.com/news/news.jsp?id=ns99993172>



The Ultimate Hype?

Lotto Sorcerer



- **Lotto Sorcerer** is a premier lottery number analysis and lottery prediction software. It uses advanced statistical analysis and fifth-generation artificial intelligence (neural network) algorithms to detect winning patterns and weighted influences in prior lottery draws, and then advises you, based on the best winning strategy. *If there is a pattern to previous winning numbers based on hot and cold numbers, **Lotto Sorcerer** will find that pattern, and recommend numbers to play accordingly.*

<http://www.satoripublishing.com/LS/ENG/>

Summary

- **The neural network bandwagon has been a bumpy ride**
- **The pioneering Wild Frontier of the 80's and early 90's has given way to a more structured and principled approach**
- **Companies now recognise and accept the limitations, but they still expect to realise tangible benefits and they are actively pursuing them**
- **There is one last person to credit ... the man who has been most responsible for raising public awareness of neural networks ...**

“I’ll be back”



No, it's not Chris Bishop!



“I’ll be backpropagating my errors”